

# WHY YOU SHOULD CHOOSE ERV.

ERV expansion joints from Elaflex are moulded single sphere type rubber bellows with swiveling metal flanges. Their construction and lengths (installation sizes) have since become internationally recognised standard.

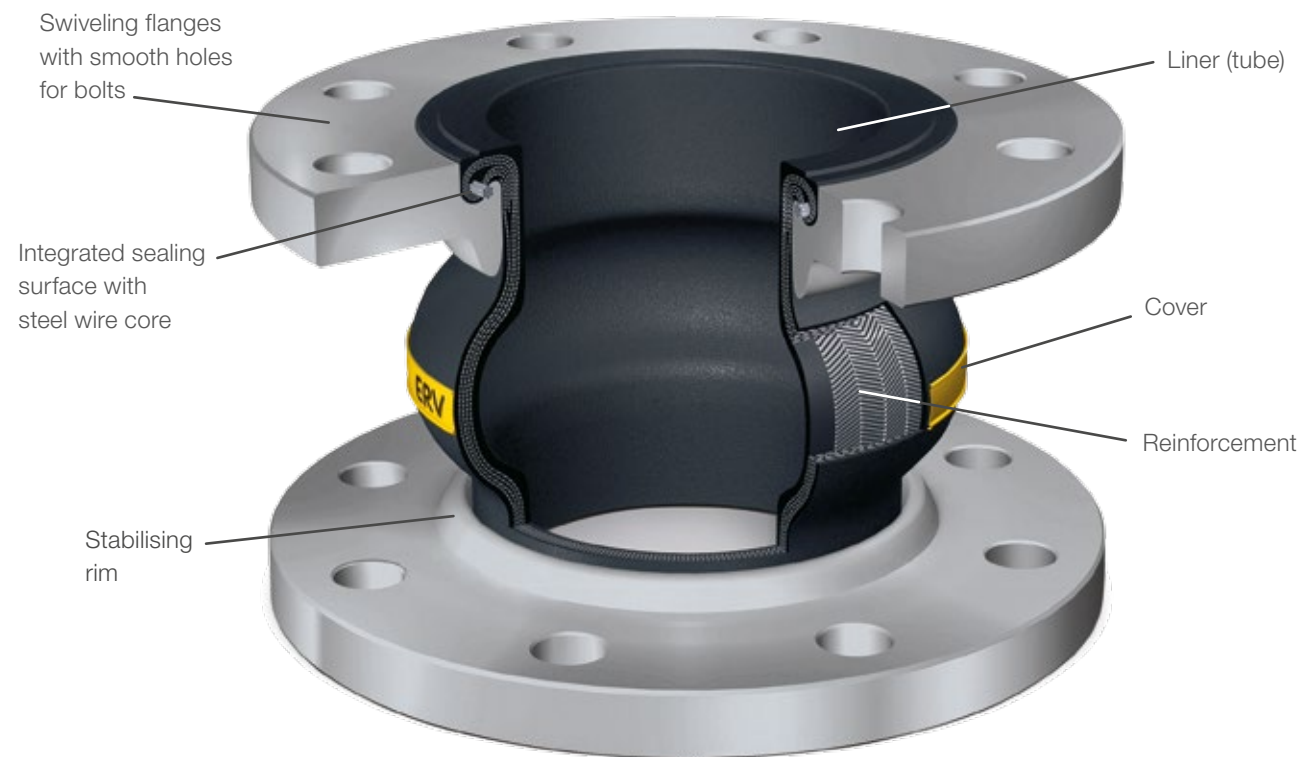

Premium products have their price. But the additional cost for ERV will pay off for the operator in the long run.

The calculation: For a defined period (e.g. 15 years), all direct and indirect costs for a product application with expansion joints are determined and added.

Cost factors include the initial product price, shipping, indirect acquisition expenses, effort for installation and inspection. Most important, the expected lifetime until replacement shall be reflected - including the often non

considered costs arising from product failure: plant downtime, environmental damage and replacement cost.

We claim that - due to their superior lifetime - ERV show the lowest Total Cost of Ownership, for the major part of applications.

Assuming proper installation and operation within their admissible operating limits, they are trustworthy components for engineers and purchasers who think and calculate in long terms.

## Optimal Shape and Construction of the Bellows

- Large axial, lateral and angular range of allowable movement, no double sphere necessary
- Low reaction forces and low inherent resistance
- Noise dampening: the major part of the piping's structure-borne noise and the low-frequency noise generated by fluids is eliminated
- Vibration dampening: ERV efficiently absorb vibrations caused by engines, turbines or compressors

## Experience and Know How

- Applications since 1956
- Useful division of labour and competence between ContiTech, one of the leading international rubber product manufacturers (bellows production) and Elaflex (know-how regarding flanges, accessories, assembling, certification, testing and distribution)
- Consistent suppliers and manufacturing methods ensure a constant quality

## Customer Focus

- Large warehouse of bellows (>25.000 bellows permanent stock) and flanges/accessories ensure short lead times for standard types
- Technical service: professional advice, documentation, testing certification (audited to European Pressure Equipment Directive)
- Online ERV configurator: <http://ervconfigurator.elaflex.de> helps to find and visualize the required product in a few seconds
- Global support by local Elaflex distribution partners

## Warranty

- Warranty period of 24 months
- Consistent quality results in a neglectable claim rate
- Each examination is free of charge, not depending on the result

## Easy Installation

- Swiveling flanges and smooth bolt holes make assembling easy
- The highly flexible bellow eases installation in problematic locations

## Superior Life Time

- HiTech rubber compounds from ContiTech
- Physical properties of compounds and reinforcements are optimised for each bellows type: elongation at break, ozone and UV resistance, cold flexibility, tensile strength, volumetric extension etc.
- Permanent testing of raw material properties – before and during production
- Rubberized reinforcements for superior adhesion of all layers
- Integrated sealing surface with type matched steel wire core
- Made in Germany, Elaflex/ContiTech quality philosophy
- High operational safety, 1:4 safety factor regarding burst pressure

## Large Product Range

- Variety of 13 different types, sizes 1" – 40" (DN 25 – 1000 mm), various lengths and a vast choice of flange type / material and accessories

## The Bellows

- International quality reference for some applications, e.g. ERV-G for tank trucks (fuels), ERV-R for drinking water, ROTEX for heating systems, ERV-OR for LP Gas
- Some unique products such as ERV-GS (ship engine room type approved), ERV-GS HNBR (large application range, temperature, abrasion & fire resistant), ERV-G LT (low temperature down to -40°C) and VITEX (FPM liner)
- Efficient due to standardised bellows lengths

## Flanges

- Modular system – flanges match with all bellows
- Certified materials, EN 10204-3.1
- Standard types with stabilising rim
- Marked with size, standard, material, manufacturer
- Cr (VI)-free corrosion protection for steel flanges long-lasting and environmentally friendly

## Certificates

- Various ERV types are certified for civil and navy ship construction, drinking water, foodstuffs, heating and gas supply installations