

**ELAFLEX Hose Reels are made from our own production and supplied as a complete package incl. hoses, couplings and nozzles.**

Hose Reels 'Modular Line M' are used for retraction of Elaflex hoses up to 50 m in max. DN 25.

It can be supplied with different rewind systems (manual, electric, hydraulic and pneumatic), resistant materials and swivel joints.

The OUT connection is placed outside the disks giving the drum more space to distribute the hose layers.

Suitable for a wide range of media, e.g. gasoline, diesel, aviation fuels, urea solution (AdBlue®), detergents, solvents, oils, water, gases and others. For example: Slimline 'SL' 25 with ZVA 25 for tank trucks with motor rewind.

Standard version is supplied with closed disks.

### CUSTOMISED VERSION

Drum diameter and disc distance can be customised to meet special requirements.

### MATERIALS

**Frame** available in polyester powder coated carbon steel UV resistant (on request: cathaphoresis treatments or zinc plated) or stainless steel (AISI 304 or AISI 316 L).

**Wet parts** available in carbon steel or stainless steel (AISI 304 or AISI 316 L).

**Swivel joint** available in zinc plated carbon steel, brass or stainless steel (AISI 303/AISI 316 L), in 90° or straight shape\*).

Working pressure up to 200 bar\*).

Temperature range -40° to +120° C\*).

\*) depending on materials

### COLOURS



RAL 5017



RAL 3002



Special Colours  
(on request)



### DIMENSIONS

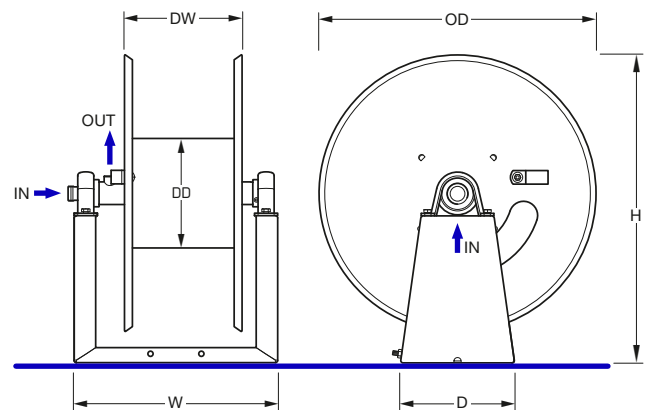

Recommended Hose		Connections	Drum Diameter	Disc Diameter	Distance btw the disks	Dimensions	Weight	Standard Part Number
max. Length	max. DN	IN / OUT	DD Ø mm	OD Ø (mm)	DW (mm)	W x D x H (mm)	kg	Type
20 m	DN 25	1" bsp male / 1" bsp female	194	490	280	360x490x545	-	HR ML M 25 L20
30 m	DN 25	1" bsp male / 1" bsp female	194	490	380	460x490x545	-	HR ML M 25 L30
40 m	DN 25	1" bsp male / 1" bsp female	194	490	480	560x490x545	-	HR ML M 25 L40
50 m	DN 25	1" bsp male / 1" bsp female	194	490	580	660x490x545	-	HR ML M 25 L50

1) Hose Reels dimensions without swivel joint and rewind system.

2) Please contact our sales team to check capacity when smaller hose diameters are required.

## SWIVEL JOINTS

### 90° SWIVEL JOINT (1)

DN 1" available in zinc plated carbon steel or stainless steel AISI 303 or brass

### STRAIGHT SWIVEL JOINT (2)

DN 1" available in zinc plated carbon steel or stainless steel AISI 316 L

## REWIND SYSTEMS

### MANUAL REWIND (3)

- with lateral handle
- direct drive

#### options:

- mechanical lock
- friction break

### HYDRAULIC REWIND (4)

- hydraulic motor with operational levers and hydraulic lock
- direct drive

#### options:

- speed control kit

### THREE PHASE ELECTRIC REWIND (5)

- electric motor 230/400V
- direct drive

#### options:

- control panel kit
- control panel kit with remote control
- mono phase inverter kit

#### on request:

- ATEX 2GD or 3GD

### ELECTRIC REWIND (6)

- electric motor 12V or 24V
- direct drive

#### options:

- control panel kit
- kit on/off
- friction break for 'E' motor

#### on request:

- ATEX 2GD or 3GD

### PNEUMATIC REWIND (7)

- pneumatic motor
- direct drive

#### option:

- kit on/off

## ACCESSORIES

### HOSE GUIDE KIT (8)

